

TECH NOTE 015

ISSUE DATE: 07-Jun-05
EXEDY REF: 015
REVISED: 04-May-07

GENERAL FITTING INSTRUCTIONS

HOW TO GET IT RIGHT THE FIRST TIME

FITTING INSTRUCTIONS... INSTALLING YOUR NEW EXEDY CLUTCH.

1: Getting it right the first time. It is vital to diagnose the cause of clutch malfunction before clutch replacement, i.e. check hydraulic system - bearing free travel - clutch cable, oil leaks and check for any signs of red dust when old clutch is being removed. Any or all of these concerns must be corrected before installing new clutch.

2: Ensure clutch supplied is correct for the application. If you're unsure, consult you're Exedy Clutch Catalogue or your supplier, as fitting a clutch to the wrong application will void the warranty.

3: Flywheel must be machined as shown below (Fig 2) or warranty will be void and check spigot bearing or the spigot bush and replace if necessary. Please note pilot/spigot bush noises are more apparent when the engine and transmission systems are cold (i.e. in the morning)

4: Before fitting, check the clutch for any shipping damage. Next clean the gearbox main drive shaft splines, then check that clutch disc slides freely on the shaft. Lightly grease the shaft splines with high melting point grease. Always ensure bell housing is degreased and is free of any dust and that fibres from the worn clutch are removed. If the clutch is a large size pull type check the ID of the bearing head for correct spline size before installation. Lack of lubrication/dry splines will cause failure to disengage gears and also cause clutch drag.

5: Check clutch release fork for cracks, check the clutch cable for stretch signs and check the release bearing guide tube for any wear. Always lightly grease the outside diameter of the tube. This will allow smooth sliding of the bearing carrier. Always check bearing on clutch release fork. Move the fork forwards and backwards i.e. in both directions, to ensure bearing is secure and does not foul any part (clutch fork or bell housing) before refitting gear box.

6: Place the clutch cover assembly over the clutch disc, after checking that the disc is the right way around and the hub section of the disc does not foul on the casting of the clutch cover assembly or the flywheel. A suitable clutch aligning tool will ensure correct alignment, assist in ease of installation and avoid spline damage. (Burr's on splines can contribute to the clutch not functioning correctly) Ensure flywheel dowels are aligned to the cover. Tighten bolts in a diagonal pattern and never use air tools to install a clutch cover assembly. Torquing down bolts in an uneven pattern can cause the lever struts to dislodge, or in the case of a diaphragm cover cause the diaphragm fingers to be uneven.

7: When the cover assembly has been torqued securely to the flywheel, ensure that the diaphragm tips (in the case of a lever type cover assembly, the release lever tips) are in a parallel position in relation to the flywheel (see Fig 3) and do not go over centre of the parallel position.

8: Re-fit gearbox, taking care not to bend the clutch disc. Never hang the gear box on the clutch disc or use any force to align gearbox shaft.

9: Check all bell housing dowels are in correct position and tighten bell housing bolts. Ensure there is no dirt or foreign material between the mating surfaces of the engine and the bell housing.

10: Perform any clutch adjustments to vehicle manufacturer's specifications.

11: Always check the clutch cable if you are unable to obtain disengagement when a new clutch is fitted. Start your checking process by replacing the cable. If it is hydraulic systems check the clutch master cylinder and the slave cylinder, ensuring there is no air in the system. This is essential to obtain maximum travel for disengagement.

12: Road test vehicle and never abuse a newly fitted clutch. Allow 1,000 km run in and always adjust free travel on your new clutch at 1,000km and 3,000 km. Thereafter, adjust at every 10,000km.

WARNING: Do not use EXEDY clutches in any situation where engine RPM's may exceed manufacturer's specifications - a pressure plate could explode unexpectedly causing serious injury or death to vehicle occupants and bystanders. Clutch cover and bell housing will not protect against exploding pressure plates. Refer Application Catalogue for correct components.

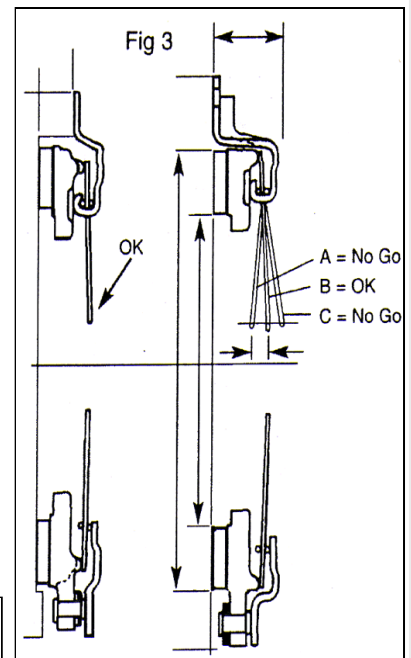
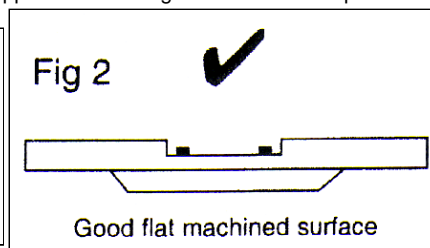
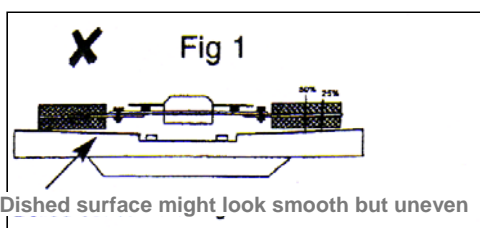

TECH NOTE 015

ISSUE DATE: 07-Jun-05
EXEDY REF: 015
REVISED: 04-May-07

GENERAL FITTING INSTRUCTIONS

Flywheel Reclamation / Resurfacing :

With the demise of Asbestos in the friction material used in clutches and the introduction of alternate materials, it is paramount that attention to the flywheel surface finish be maintained.

To enhance the performance of the clutch and reduce the risk of shudder, the flywheel surface finish should replicate that of the pressure plate friction face of the new Exedy cover assembly.

Preferably by grinding, remove all traces of "hot spots" and/or grooving and maintain the correct flywheel profile ie flat, raised or recessed. Any deviation may have a detrimental influence on the operation of the clutch.



Fig: 4 & 5

"This flywheel has been machined with a polish finish which may promote clutch shudder"

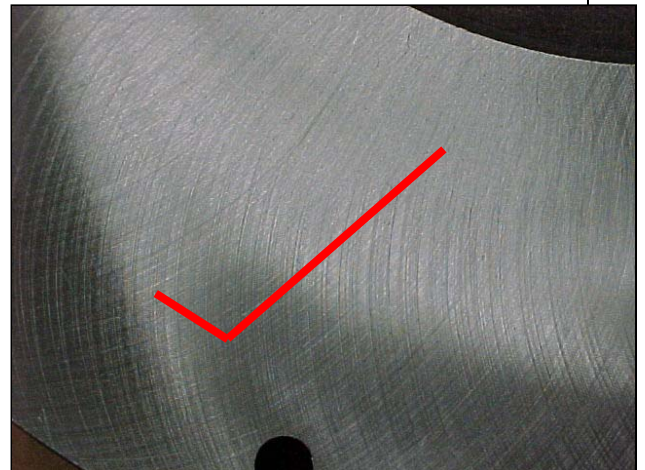
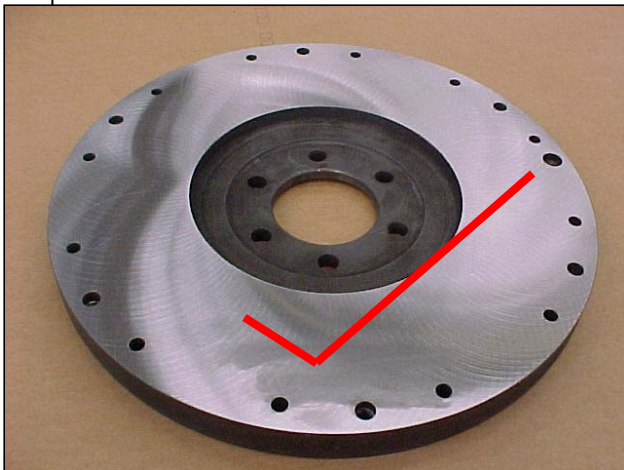

Fig: 6 & 7

"This flywheel has been ground to replicate the surface finish of its mating cover assembly which will reduce the risk of clutch shudder"