

# TECH NOTE 016

**ISSUE DATE:** 30-May-05  
**EXEDY REF:** 016  
**REVISED DATE:** 19-Aug-05

## POOR CLUTCH RELEASE HOLDEN RODEO 2.8 LTR DIESEL TURBO

It has been found that disengagement concern experienced with the subject vehicles have been incorrectly diagnosed as a faulty clutch.

This incorrect diagnosis has resulted in a clutch kit being fitted, followed by the fitting of replacement Master and Slave Cylinders, and the vehicle still found to have a gear selection problem.

These vehicles are fitted with a Clutch Damper similar to that illustrated between the Clutch Master Cylinder and the Slave Cylinder.

It has been found that the Clutch Damper has been the cause of the problem, with the cup bypassing fluid and or the Damper Rubber compressing, which in turn restricts the fluid flow necessary to obtain the required slave cylinder travel.

Should you experience the subject concern, if you find you are able to lever the fork a little further, and the clutch releases correctly then the concern is likely to be the Clutch Damper.

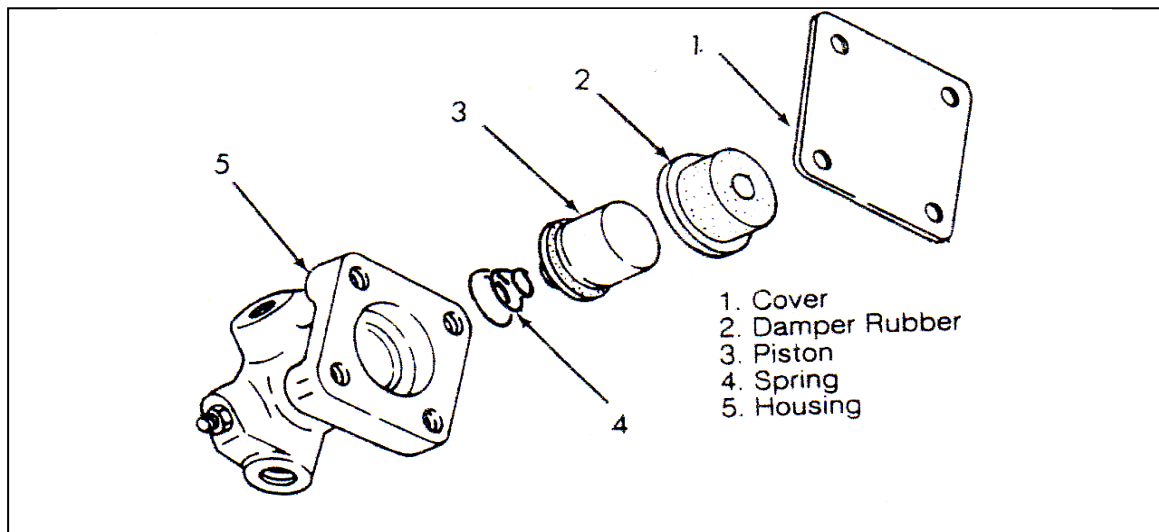

To test if the Clutch Damper is at fault, make an hydraulic line to bypass the Damper, or use a suitable size joiner, if the clutch then operates correctly, the Clutch Damper should be replaced. It has been found replacement of the cup only in the Damper has not rectified the concern.

EXEDY Australia recommends that it is important the Damper is replaced and not substituted by the hydraulic bypass line or joiner.