

TECH NOTE 027

ISSUE DATE: 27-Nov-07
EXEDY REF: 027

EUROPEAN HEAVY TRUCK – PULL TYPE CLUTCH - RELEASE BEARING FITTING GUIDE

BEARING TO PULL TYPE COVER FITTING INSTRUCTIONS

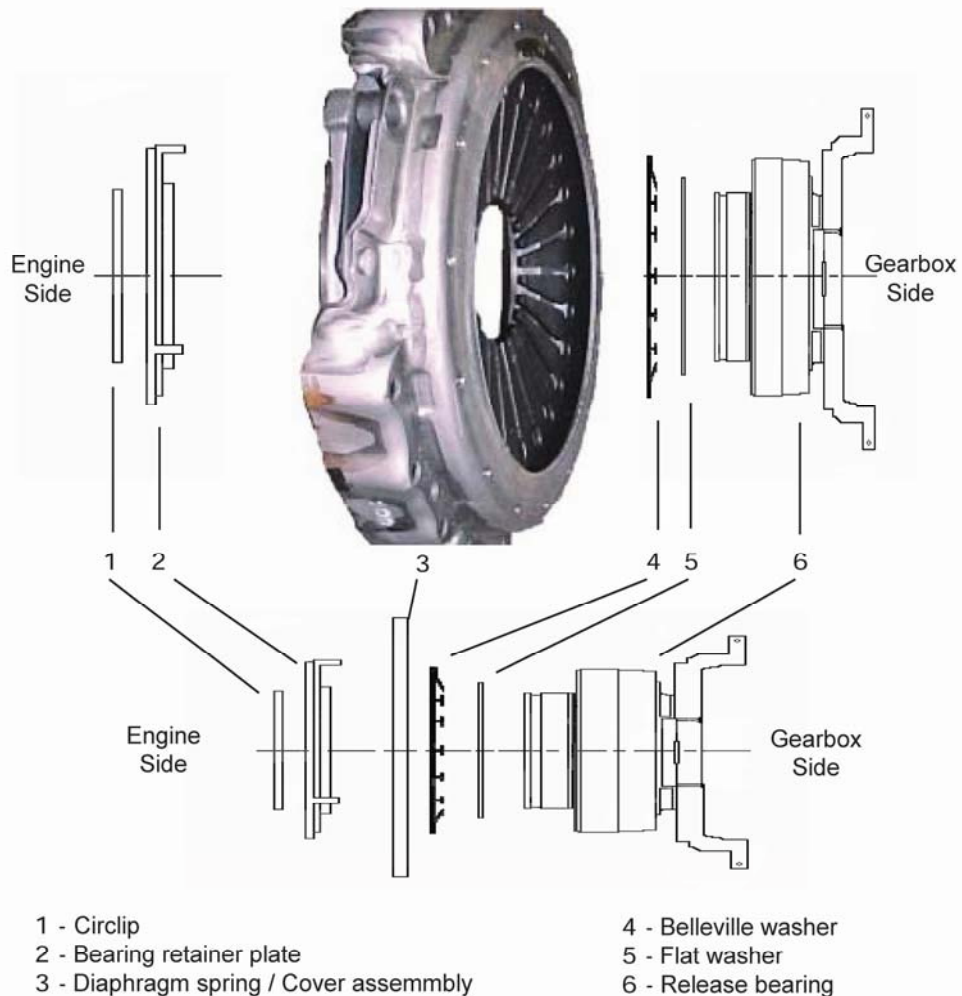

ASSEMBLY SEQUENCE

- A : Place flat washer (5) onto the engine side of the release bearing (6), followed by the belleville washer(4). Ensure, that the smaller side of belleville washer faces the release bearing.
- B : Push the release bearing through the diaphragm spring (3) from the gearbox side.
- C : Fit bearing retainer plate (2) to the release bearing from the engine side of the diaphragm spring and securely attach the circlip (1) fitting to the circlip groove in the release bearing.